

LV8411GR — Bi-CMOS LSI For DSC, and Cell Phone Camera Modules 4-channel Single-chip Motor Driver IC

Overview

The LV8411GR is an H- bridge motor driver IC and is able to control 4 modes of forward, reverse, brake, and standby.

This IC housed in a miniature package is optimum for use in a stepping motor driving system for DSC or a camera module of cell phones.

Features

- Saturation drive H bridge: 4 channels
- Built-in thermal protection circuit
- Built-in low voltage malfunction prevention circuit
- Incorporates a transistor for driving photosensors

Typical Applications

- Digital still camera (DSC)
- Camera module of cell phones

Pin Assignment

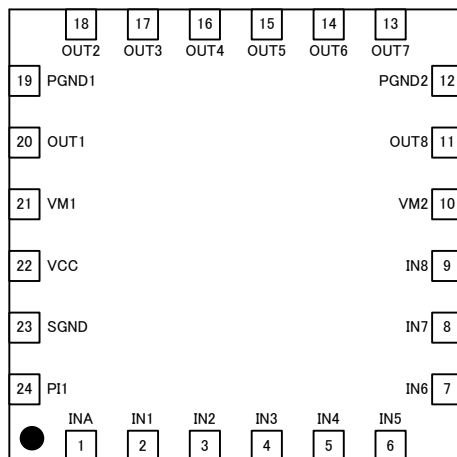

(Top view)

Package Dimensions

Unit : mm(typ)

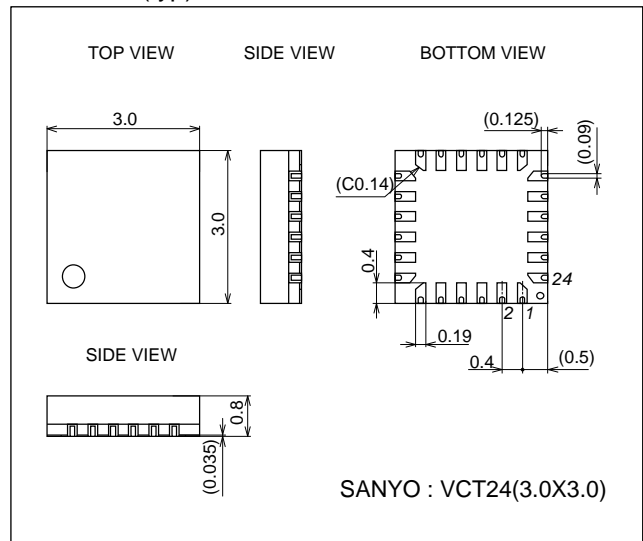

Mounting pad sketch

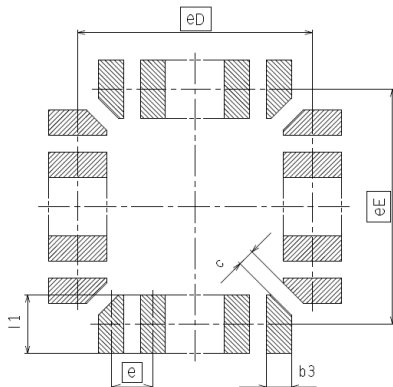

Unit : mm

Reference Symbol	VCT24(3.0x3.0)
eD	2.70
eE	2.70
e	0.40
b3	0.19
l1	0.70
c	0.20

Caution: The package dimension is a reference value, which is not a guaranteed value.

LV8411GR

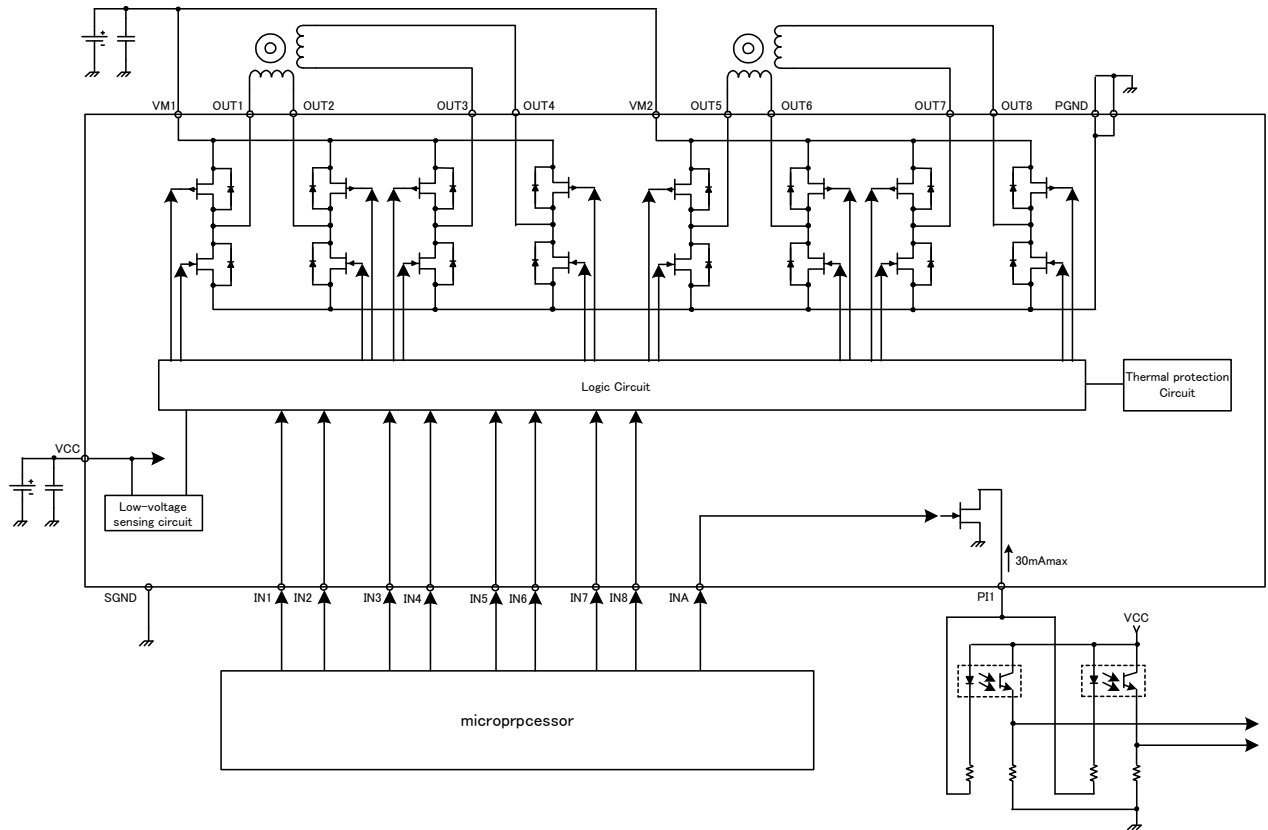

Figure 1. Block Diagram

LV8411GR

Specifications

Absolute Maximum Ratings at Ta = 25°C

Parameter	Symbol	Conditions	Ratings	Unit
Power supply voltage 1	V _M max		6.0	V
Power supply voltage 2	V _{CC} max		6.0	V
Output peak current	I _O peak	Channels 1 to 4, t ≤ 10msec, ON-duty ≤ 20%	600	mA
Output continuous current 1	I _O max1	Channels 1 to 4	400	mA
Output continuous current 2	I _O max2	PI1	30	mA
Allowable power dissipation	Pd max	Mounted on a circuit board*	1.05	W
Operating temperature	T _{opr}		-30 to +85	°C
Storage temperature	T _{stg}		-55 to +150	°C

* Specified circuit board : 40mm×50mm×0.8mm : glass epoxy four-layer board

Recommended Operating Conditions at Ta=25°C

Parameter	Symbol	Conditions	Ratings	Unit
Power supply voltage range 1	V _M		2.5 to 5.5	V
Power supply voltage range 2	V _{CC}		2.5 to 5.5	V
Logic input voltage range	V _{IN}		0 to V _{CC} +0.3	V
Input frequency	f _{IN}	IN1 to 8, INA	to 100	kHz

Electrical Characteristics at Ta=25°C, V_M=5.0V, V_{CC}=3.3V, unless otherwise specified.

Parameter	Symbol	Conditions	Ratings			Unit
			min	typ	max	
Standby mode current drain	I _{stn}	IN1 to 8 = "L"			1.0	μA
V _M current drain	I _M	IN1 = "H", IM1 + IM2, with no load	50	100	200	μA
V _{CC} current drain	I _{CC}	IN1 = "H"	0.3	0.6	1.2	mA
V _{CC} low-voltage cutoff voltage	V _{thV_{CC}}		2.0	2.25	2.5	V
Low-voltage hysteresis voltage	V _{thHIS}		100	150	200	mV
Thermal shutdown temperature	TSD	Design guarantee value *	160	180	200	°C
Thermal hysteresis width	ΔTSD	Design guarantee value *	10	30	50	°C
OUT1 to 8						
Logic pin internal pull-down resistance	R _{in}	IN1 to 8	50	100	200	kΩ
Logic pin input current	I _{inL}	V _{IN} = 0V, IN1 to 8			1.0	μA
	I _{inH}	V _{IN} = 3.3V, IN1 to 8	16.5	33	60	μA
Logic input high-level voltage	V _{inh}	IN1 to 8	2.5			V
Logic input low-level voltage	V _{inl}	IN1 to 8			1.0	V
Output on-resistance	R _{onu}	I _O = 400mA, upper ON resistance		0.75	0.9	Ω
	R _{ond}	I _O = 400mA, lower ON resistance		0.45	0.6	Ω
Output leakage current	I _{Oleak}				1.0	μA
Diode forward voltage	V _D	ID = -400mA	0.7	0.9	1.2	V
PI1						
Logic pin internal pull-down resistance	R _{in}	INA	50	100	200	kΩ
Logic pin input current	I _{inL}	V _{IN} = 0V, INA			1.0	μA
	I _{inH}	V _{IN} = 3.3V, INA	16.5	33	60	μA
Logic input high-level voltage	V _{inh}	INA	2.5			V
Logic input low-level voltage	V _{inl}	INA			1.0	V
Output on-resistance	R _{on}	I _O = 10mA		3.0	6.0	Ω
Output leakage current	I _{Oleak}				1.0	μA

LV8411GR

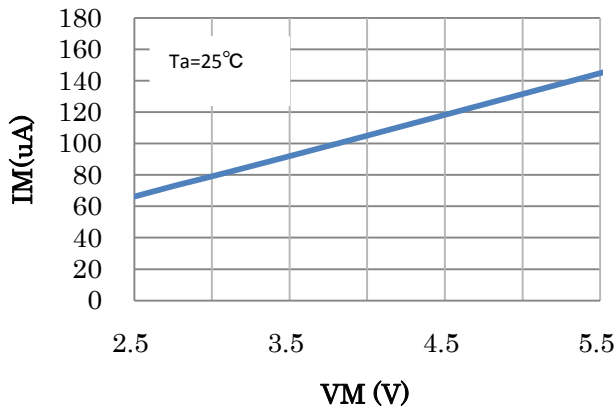

Figure 2. VM current drain vs. VM supply voltage

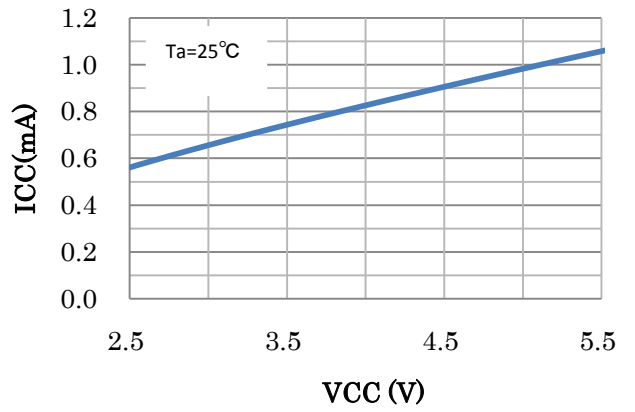

Figure 3. VCC current drain vs. VCC supply voltage

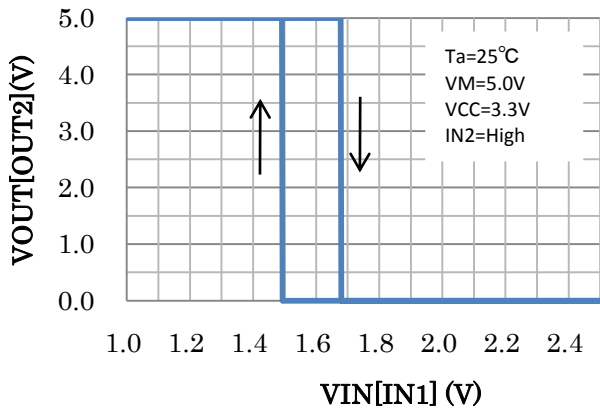

Figure 4. Output voltage vs. Input voltage

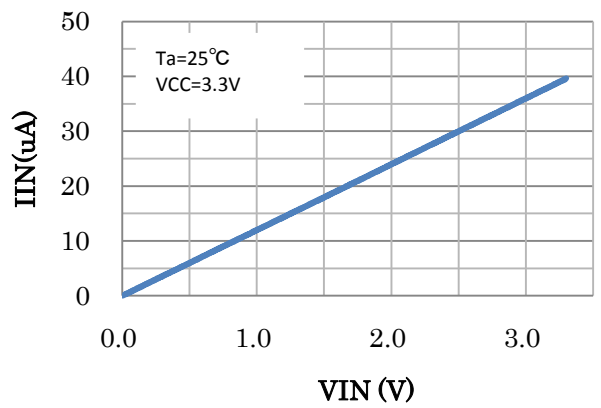

Figure 5. Input current vs. Input voltage

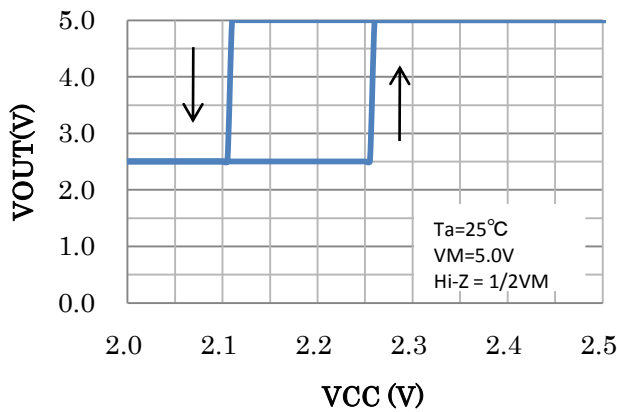

Figure 6. VCC low voltage protection characteristic

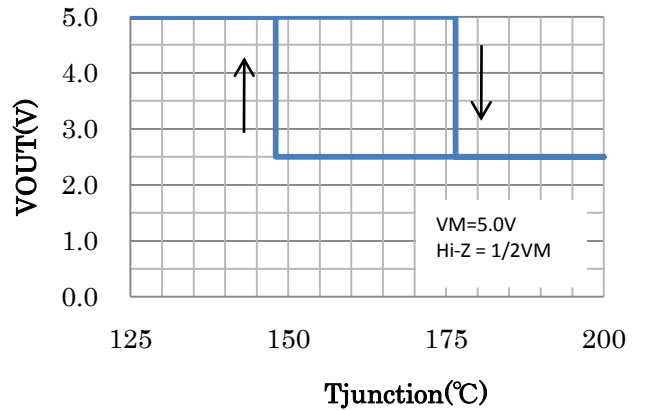

Figure 7. Thermal protection characteristic

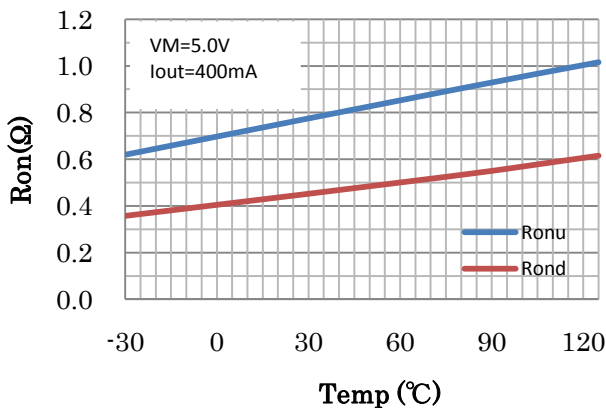

Figure 8. Output on-resistance vs. Temperature

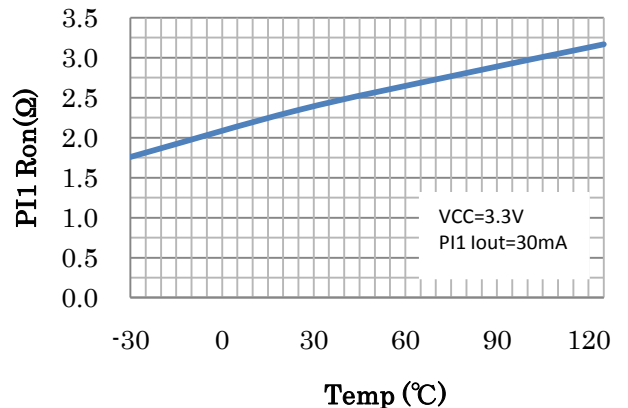

Figure 9. PI1 on-resistance vs. Temperature

LV8411GR

Pin Functions

Pin No.	Pin name	Pin Function	Equivalent Circuit
1	INA	Control signal input pin (Photo sensor driving transistor) When High, P11 operates. With 100KΩ of pulldown resistor, when OPEN, the operation is equivalent to that of Low control signal. PWM control is feasible when input frequency is 100KHz or lower.	
2 3 4 5 6 7 8 9	IN1 IN2 IN3 IN4 IN5 IN6 IN7 IN8	Control signal input pin When the voltage level is High, all the outputs that correspond to inputs are activated. Since 100KΩ of pull-down resistor is inserted, when OPEN the operation is equivalent to that of Low control signal. PWM control is feasible when the input frequency is 100KHz or lower.	
11 13 14 15 16 17 18 20	OUT8 OUT7 OUT6 OUT5 OUT4 OUT3 OUT2 OUT1	Output pin This pin is connected to the motor. Operation mode is determined according to the state of control signal input pins.	

LV8411GR

Pin No.	Pin name	Pin Function	Equivalent Circuit
24	PI1	Photo sensor driving transistor output pin ON/OFF of the internal Nch MOS is determined according to the state of INA	
22	VCC	Logic system power supply connection pin Supply voltage range is between 2.5V and 5.5V. To stabilize VCC power line, connect a bypass capacitor between this pin and SGND(pin 23).	
10 21	VM2 VM1	Motor power supply connection pin Supply voltage range is between 2.5V and 5.5V. To stabilize VM power line, connect a bypass capacitor between these pins and PGND(12,19pin) respectively.	
23	SGND	Signal ground	
12 19	PGND2 PGND1	Power ground	

Operation explanation

Saturation drive H bridge

4-channels H bridge drivers are integrated independently which enable controlling 4 modes: forward, reverse, brake, and standby.

Logic input specifications

- Common channels 1 to 4
- ch1 : IN1 to IN2, OUT1 to OUT2
- ch2 : IN3 to IN4, OUT3 to OUT4
- ch3 : IN5 to IN6, OUT5 to OUT6
- ch4 : IN7 to IN8, OUT7 to OUT8

Input		Output		Operation mode
IN1	IN2	OUT1	OUT2	
L	L	OFF	OFF	Standby
H	L	H	L	CW (forward)
L	H	L	H	CCW (reverse)
H	H	L	L	Brake

When IN1 to IN8 are “Low”, the operation of H bridge output stage is in standby mode. When “high” is applied to an input pin that corresponds to each channel, the output transistor of the H- bridge output stage operates and the operation shifts as follows: forward, reverse, and brake.

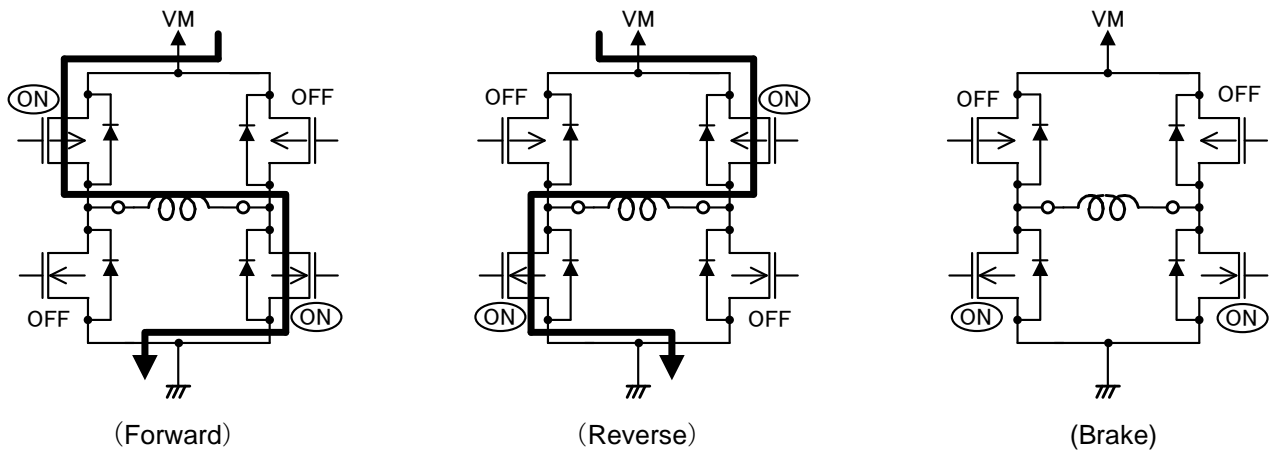

Figure 10. Output stage transistor function

• Photo sensor driving transistor

By setting INA to High, Nch transistor for driving photo sensor operates. Since you can sink constant current of 30mA at a maximum, this motor driver can be used for LED.

When thermal shutdown and V_{CC} low-voltage cut circuits are activated, OUT1 through OUT8 are turned OFF under control of the internal circuit. But the output (PI1) of photo sensor driving transistor continues operation.

Input	Photo sensor driving PI1
L	OFF
H	ON

Thermal protection

This IC includes thermal shutdown circuit.

The thermal shutdown circuit is incorporated and the output is turned off when junction temperature T_j exceeds 180°C . As the temperature falls by hysteresis, the output is turned on again (automatic restoration).

The thermal shutdown circuit does not guarantee the protection of the final product because it operates when the temperature exceeds the junction temperature of $T_{j\text{max}}=150^{\circ}\text{C}$.

Thermal hysteresis width is the difference of temperature between the start of thermal shutdown and auto recovery.

Thermal shutdown temperature = 180°C (typ)

Thermal hysteresis width = 30°C (typ)

VCC Low voltage malfunction prevention

This IC includes the function of VCC Low voltage malfunction prevention.

When the supply voltage of VCC lowers down to approximately 2.25V (typ), H bridge output stage shifts from operation mode to standby mode. On the other hand, when the supply voltage of VCC increases to approximately 2.4V , H bridge output stage shifts to operation mode.

Low-voltage hysteresis voltage is the difference of VCC electric potential between VCC increase and decrease where switch of H bridge output stage occurs.

VCC low-voltage cutoff voltage = 2.25V (typ)

Low-voltage hysteresis voltage = 150mV (typ)

LV8411GR

Application Circuit Example

•2phase excitation mode setting of stepping motor

A stepping motor can be driven through 2-phase excitation mode by switching input signal as follows.

INPUT				OUTPUT				Position No.
IN1	IN2	IN3	IN4	OUT1	OUT2	OUT3	OUT4	
H	L	L	H	H	L	L	H	(1)
H	L	H	L	H	L	H	L	(2)
L	H	H	L	L	H	H	L	(3)
L	H	L	H	L	H	L	H	(4)

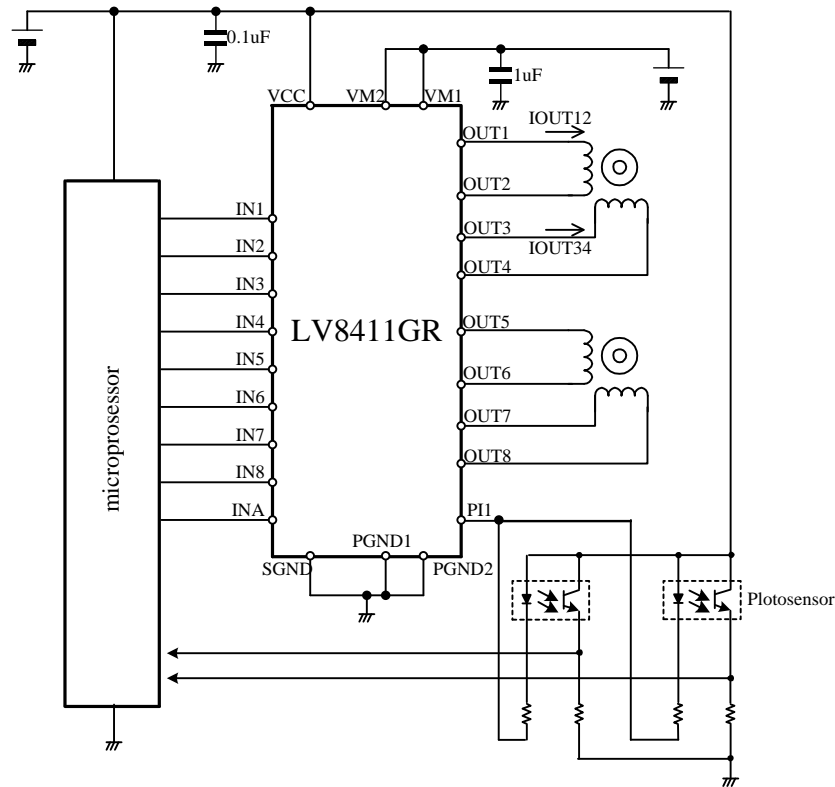

**Figure 11. Sample Application Circuit
(Stepping motor drive circuit)**

Bypass capacitor has no specific regulation on electrolytic capacitor or ceramic capacitor. However, it is recommended that the capacitor with large capacitance is connected adjacent to supply pin and GND to ensure that it can control voltage fluctuation of the supply line sufficiently. When capacitor with high capacitance is used, charge current to capacitor increases. Hence, caution is required for the battery's capability of current supply.

Recommendation value

Between VM and PGND: 1.0uF or higher

Between VCC and SGND: 0.1uF or higher

LV8411GR

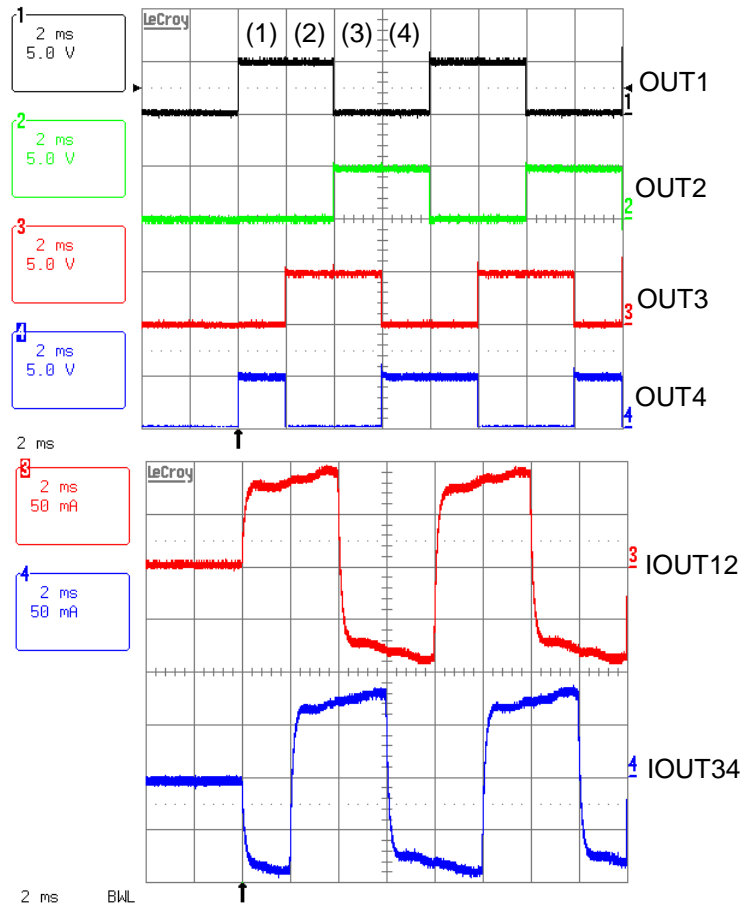
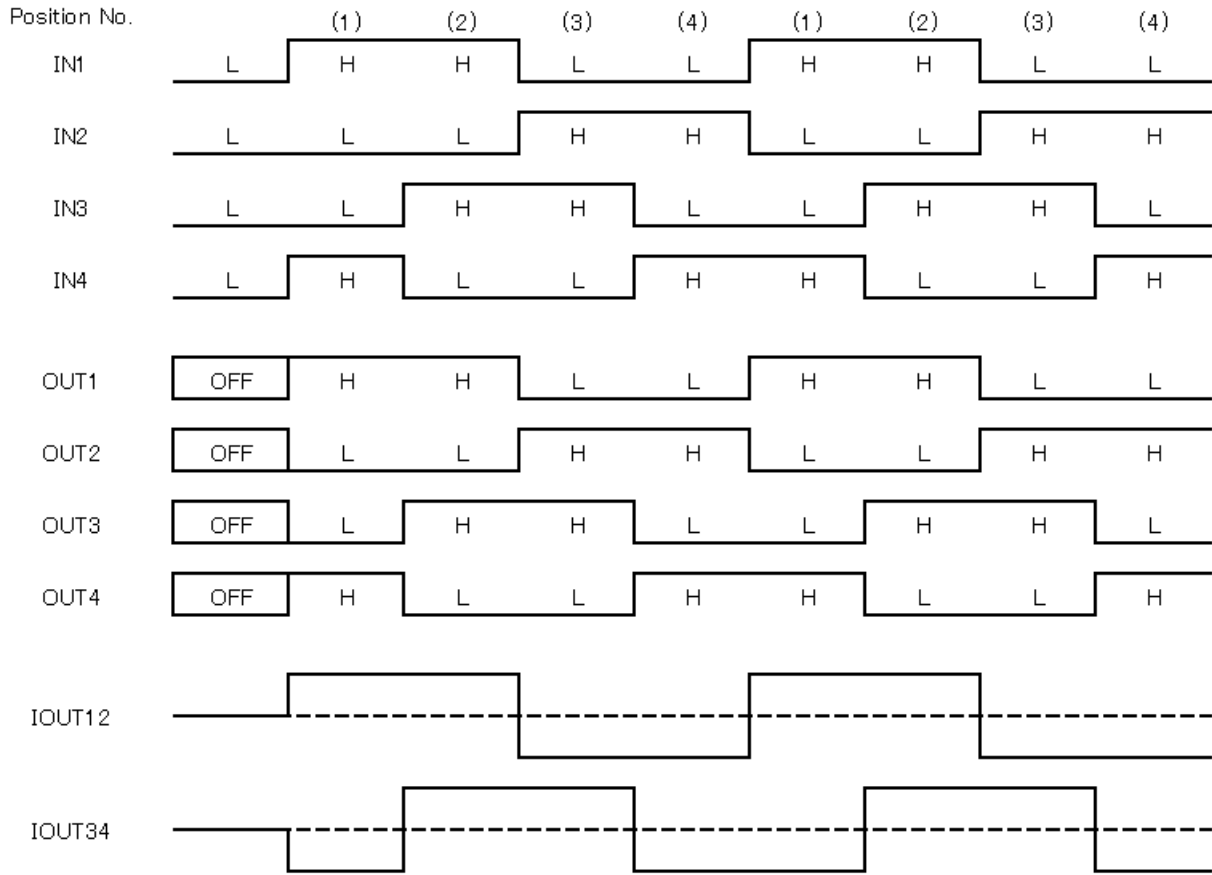

Figure 12. Timing chart for stepping motor 2phase excitation

LV8411GR

•1-2phase excitation mode setting of stepping motor

A stepping motor can be driven through 1-2-phase excitation mode by switching input signal as follows.

INPUT				OUTPUT				Position No.
IN1	IN2	IN3	IN4	OUT1	OUT2	OUT3	OUT4	
H	L	L	H	H	L	L	H	(1)
H	L	L	L	H	L	OFF	OFF	(2)
H	L	H	L	H	L	H	L	(3)
L	L	H	L	OFF	OFF	H	L	(4)
L	H	H	L	L	H	H	L	(5)
L	H	L	L	L	H	OFF	OFF	(6)
L	H	L	H	L	H	L	H	(7)
L	L	L	H	OFF	OFF	L	H	(8)

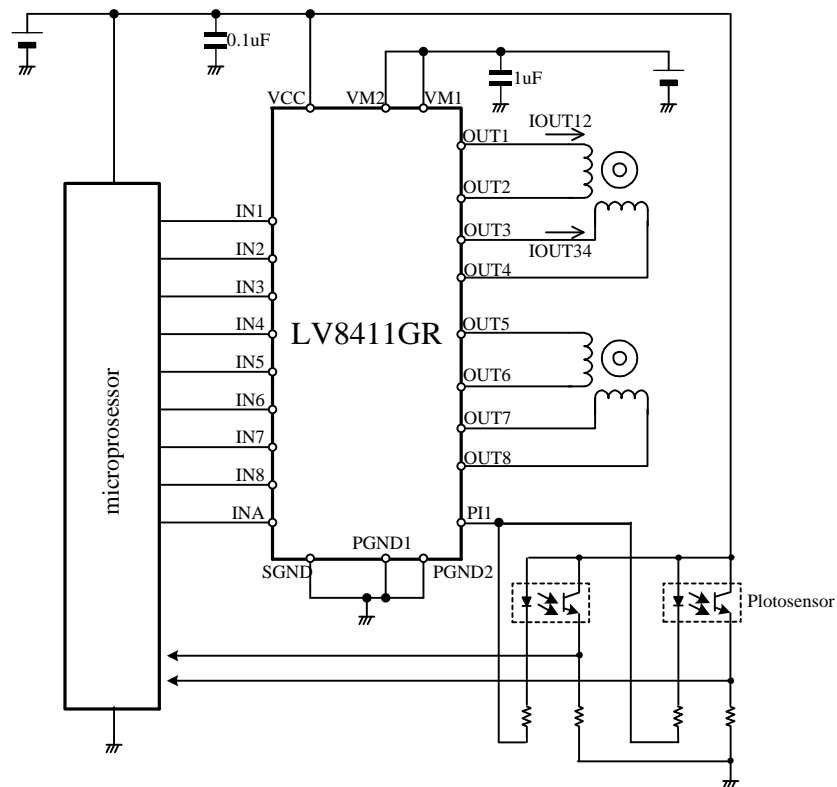
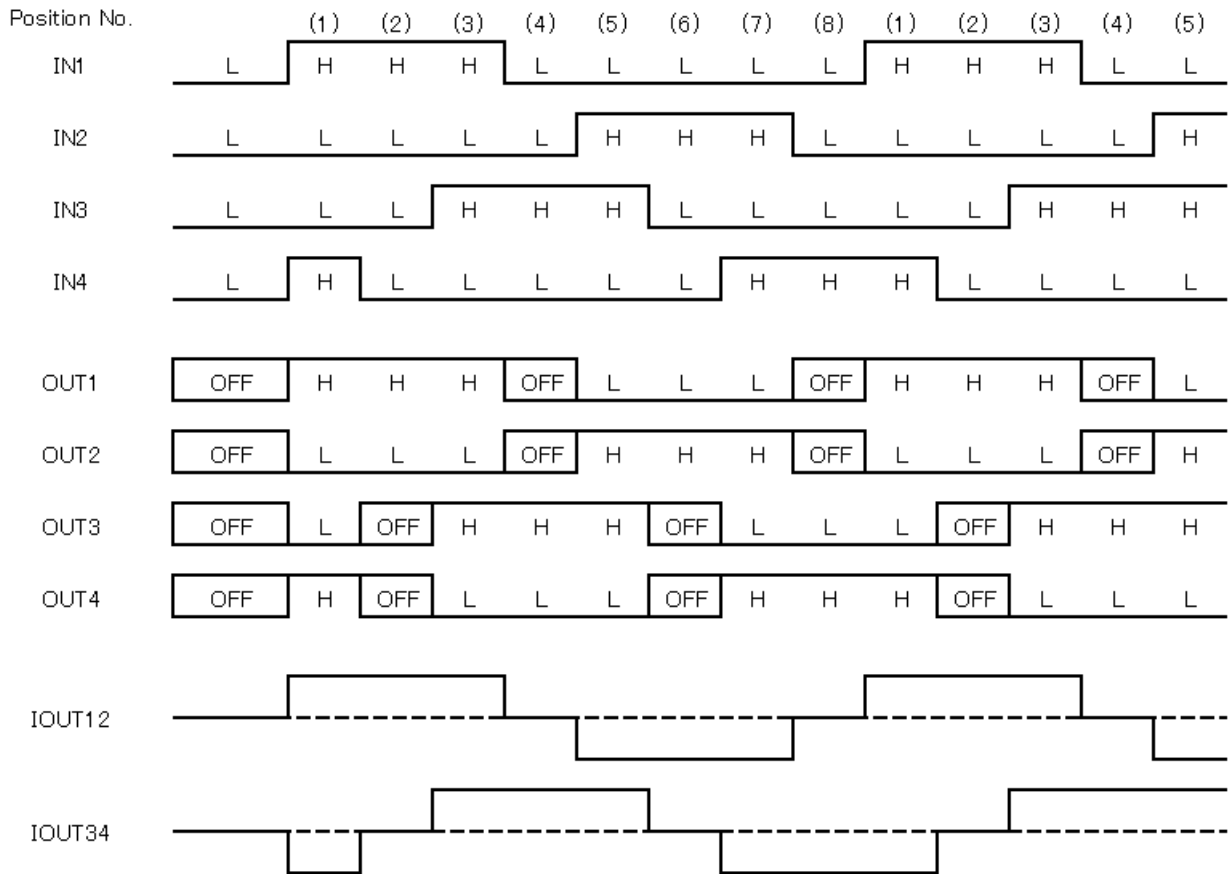

Figure 13. Stepping motor drive circuit

LV8411GR



The kickback is generated by the coil component of the motor.

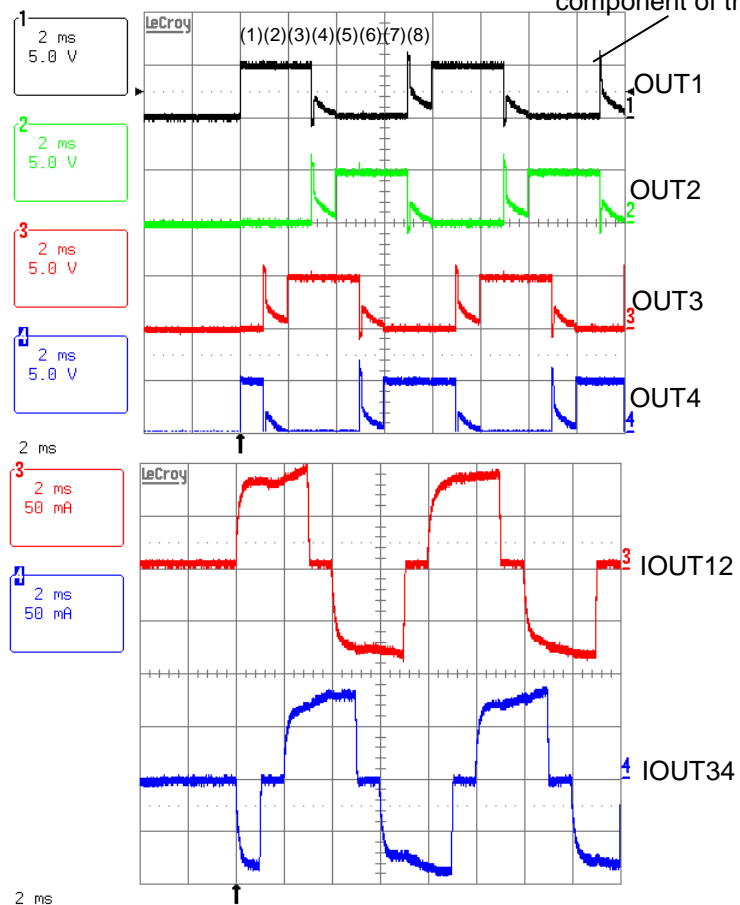

Figure 14. Timing chart for stepping motor 1-2phase excitation

LV8411GR

•Operation setting of DC motor

CW(forward)

INPUT		OUTPUT		Condition.
IN1	IN2	OUT1	OUT2	
H	L	H	L	CW(forward)
H	H	L	L	Brake

CCW (reverse)

INPUT		OUTPUT		Condition.
IN1	IN2	OUT1	OUT2	
L	H	L	H	CCW (reverse)
H	H	L	L	Brake

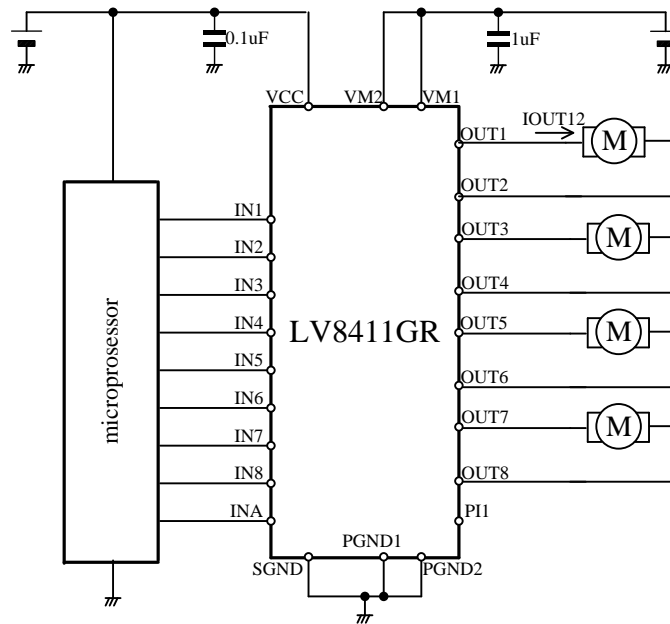
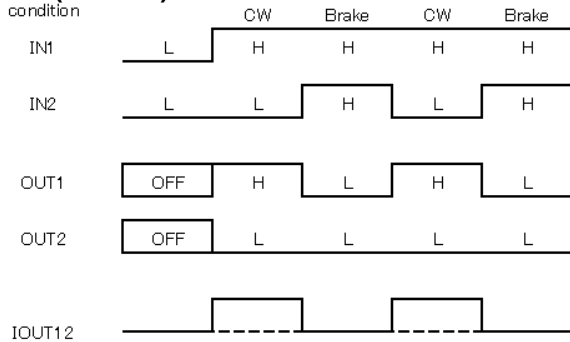

Figure 15. DC motor drive circuit

CW(forward)



CCW(reverse)

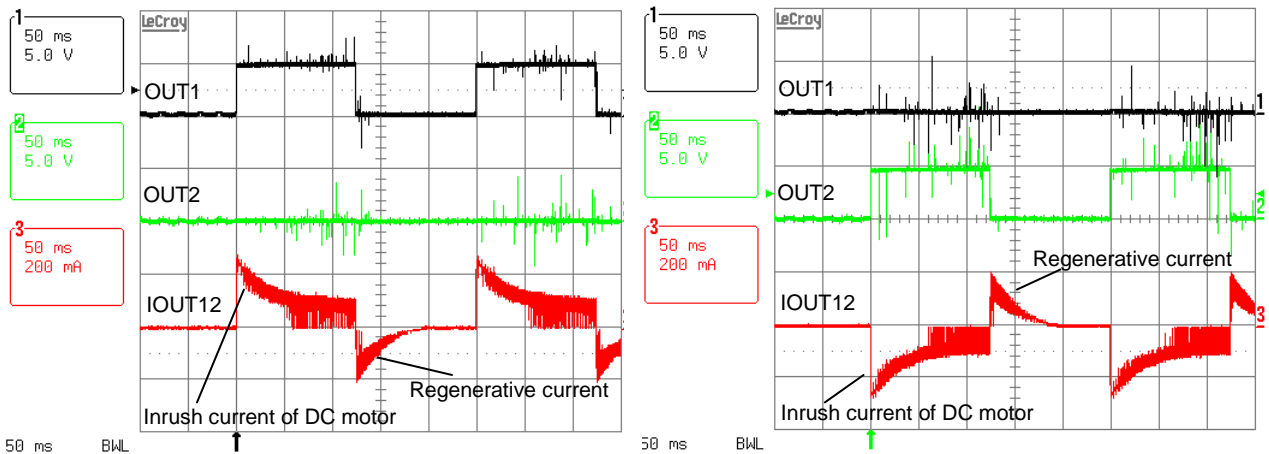
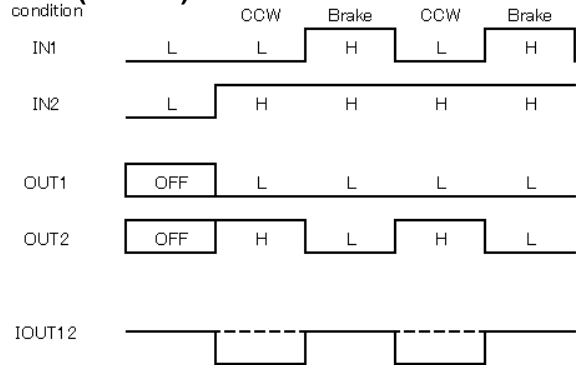

Figure 16. Driving waveform of DC motor

LV8411GR

Input and output characteristics of H-Bridge

LV8411GR can be driven by direct PWM control of H-Bridge by inputting PWM signal to IN. However output response of H-Bridge worsens around On-duty 0%, which generates dead zone. As a result, IC control loses linearity. If you intend to drive motor in such control range, make sure to check the operation of your motor.

Input-Output Characteristics of H-Bridge (reference data)

Forward/Reverse ⇔ Brake

VM=5.0V

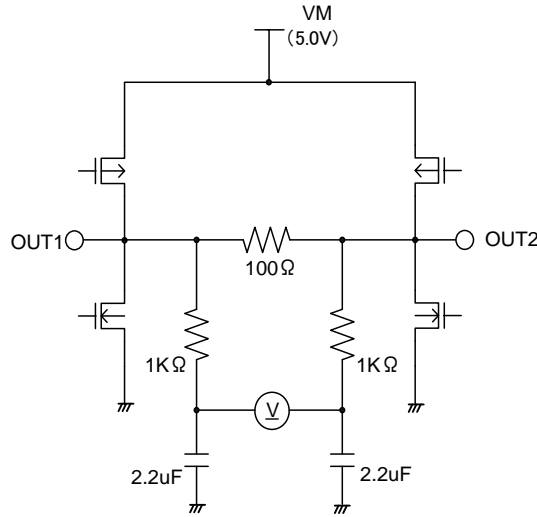

Figure 17. Measurement connection diagram

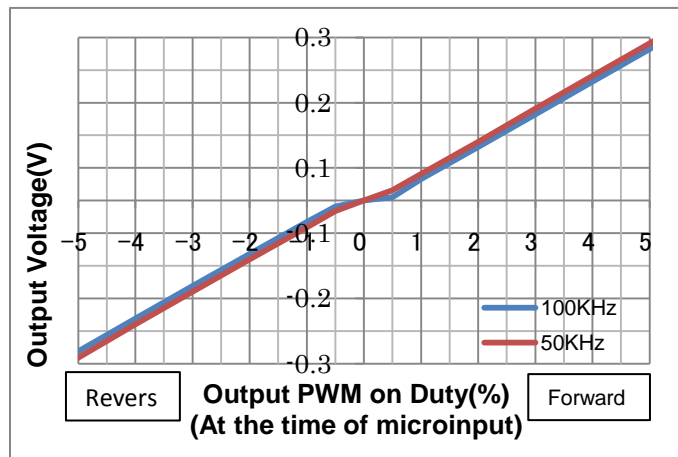
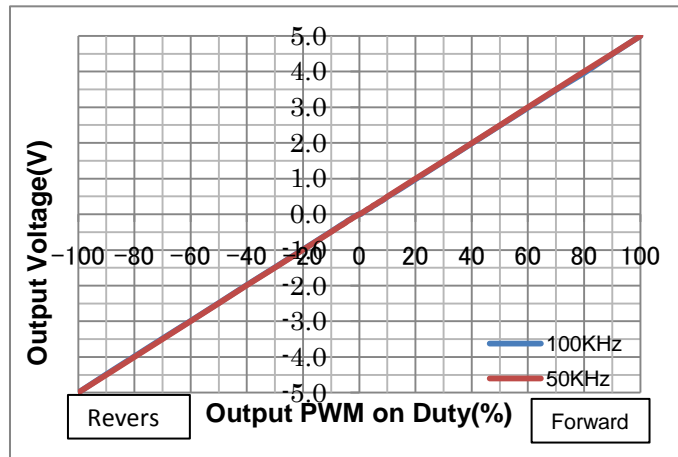
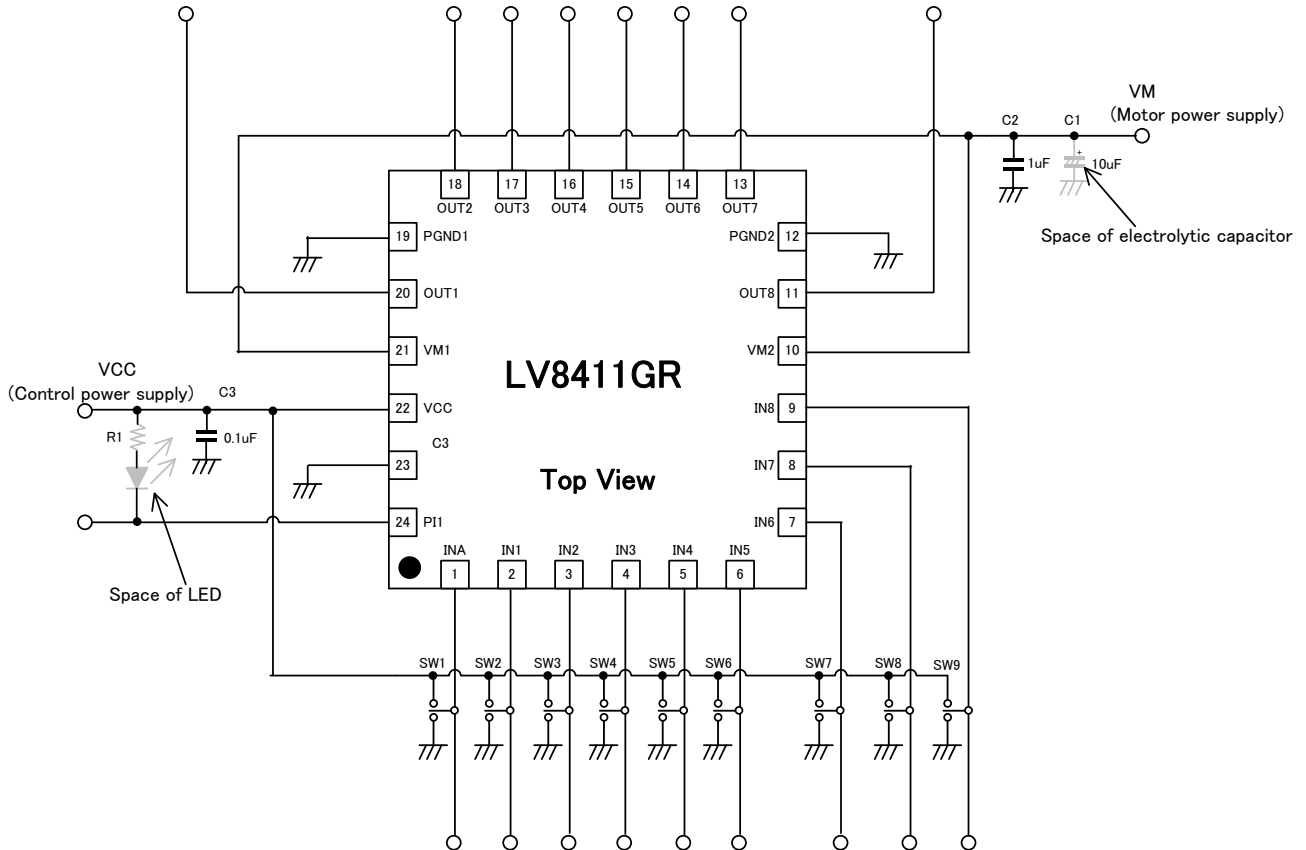

Figure 18. Input and Output Characteristics of H-Bridge

LV8411GR

Evaluation Board Manual

1. Evaluation Board circuit diagram



Bill of Materials for LV8411GR Evaluation Board

Designator	Qty	Description	Value	Tol	Footprint	Manufacturer	Manufacturer Part Number	Substitution Allowed	Lead Free
IC1	1	Motor Driver			VCT24 (3.0×3.0)	SANYO semiconductor	LV8411GR	No	Yes
C1	1	VM Bypass capacitor	10µF					Yes	
C2	1	VM Bypass capacitor	1.0µF 10V	10%	1608	Murata	GRM188B11A 105K	Yes	Yes
C3	1	VCC Bypass capacitor	0.1µF 100V	10%	1608	Murata	GRM188R72A 104KA35D	Yes	Yes
R1	1	LED current limitation resistance						Yes	
LED	1	Substitution of photo sensor						Yes	
SW1-SW9	9	Switch				MIYAMA	MS-621-A01	Yes	Yes
TP1-TP20	20	Test points				MAC8	ST-1-3	Yes	Yes

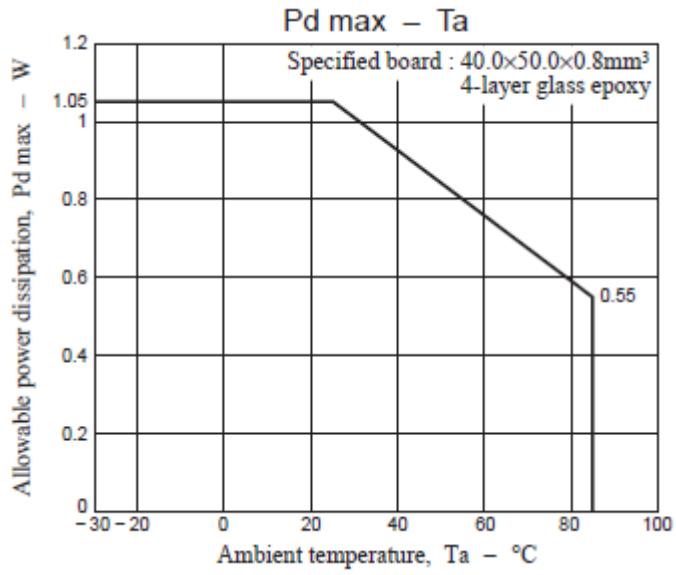

Evaluation Board PCB Design

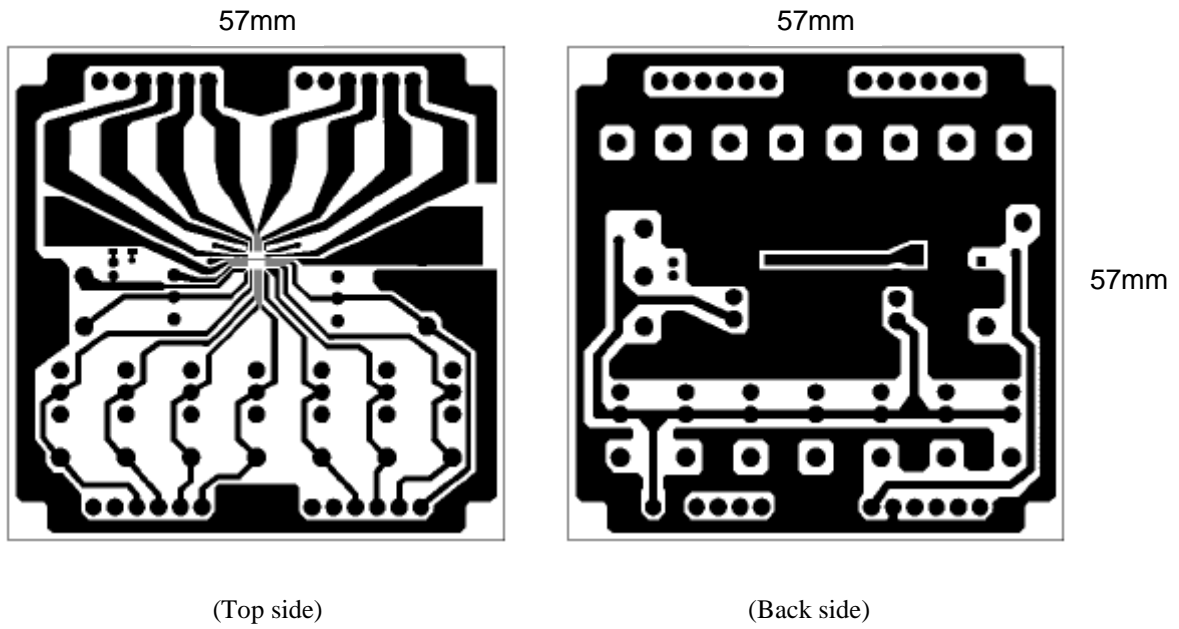

LV8411GR

2. Two stepping motor drive

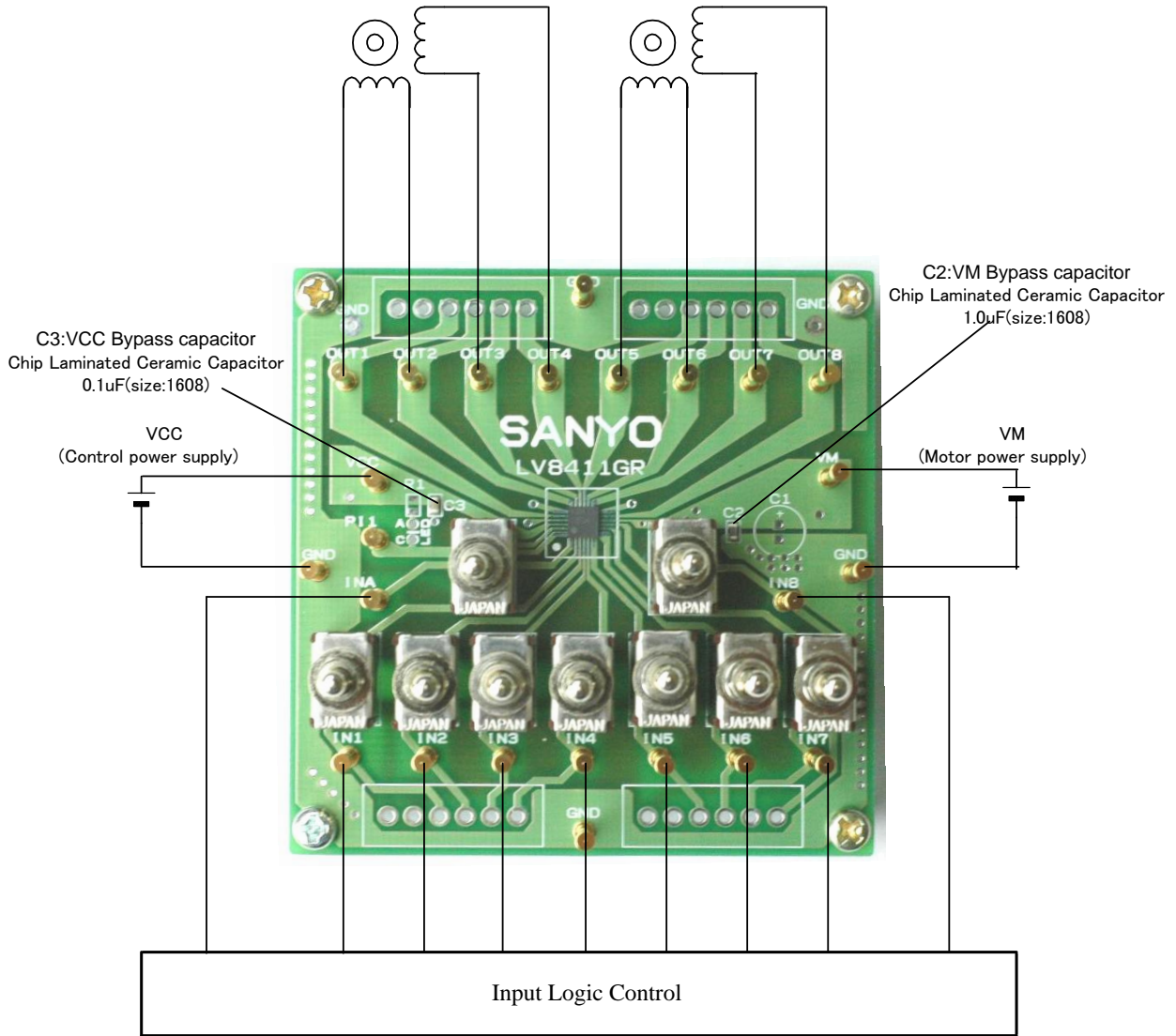

- Connect a stepping motor 1 with OUT1, OUT2, OUT3 and OUT4.
- Connect a stepping motor 2 with OUT5, OUT6, OUT7 and OUT8.
- Connect the motor power supply with the terminal VM, the control power supply with the terminal VCC. Connect the GND line with the terminal GND.
- You can drive stepping motor through 2-phase excitation mode by switching input signal as follows. In the case of stepping motor 2, switch IN5 to IN8 in the same way.

INPUT				OUTPUT				Position No.
IN1	IN2	IN3	IN4	OUT1	OUT2	OUT3	OUT4	
H	L	L	H	H	L	L	H	(1)
H	L	H	L	H	L	H	L	(2)
L	H	H	L	L	H	H	L	(3)
L	H	L	H	L	H	L	H	(4)

LV8411GR

For 1-2-phase excitation mode, switch input signal as follows.

INPUT				OUTPUT				Position No.
IN1	IN2	IN3	IN4	OUT1	OUT2	OUT3	OUT4	
H	L	L	H	H	L	L	H	(1)
H	L	L	L	H	L	OFF	OFF	(2)
H	L	H	L	H	L	H	L	(3)
L	L	H	L	OFF	OFF	H	L	(4)
L	H	H	L	L	H	H	L	(5)
L	H	L	L	L	H	OFF	OFF	(6)
L	H	L	H	L	H	L	H	(7)
L	L	L	H	OFF	OFF	L	H	(8)

*The descriptions in p.8 to p.11 are the same as the description in this section.

- By setting INA to High, Nch transistor for photo sensor operates.
Since you can sink constant current of 30mA at a maximum, this motor driver can be used for LED.
If necessary, please use LED to confirm the operation of the IC.

- Any and all SANYO Semiconductor Co.,Ltd. products described or contained herein are, with regard to "standard application", intended for the use as general electronics equipment (home appliances, AV equipment, communication device, office equipment, industrial equipment etc.). The products mentioned herein shall not be intended for use for any "special application" (medical equipment whose purpose is to sustain life, aerospace instrument, nuclear control device, burning appliances, transportation machine, traffic signal system, safety equipment etc.) that shall require extremely high level of reliability and can directly threaten human lives in case of failure or malfunction of the product or may cause harm to human bodies, nor shall they grant any guarantee thereof. If you should intend to use our products for applications outside the standard applications of our customer who is considering such use and/or outside the scope of our intended standard applications, please consult with us prior to the intended use. If there is no consultation or inquiry before the intended use, our customer shall be solely responsible for the use.
- Specifications of any and all SANYO Semiconductor Co.,Ltd. products described or contained herein stipulate the performance, characteristics, and functions of the described products in the independent state, and are not guarantees of the performance, characteristics, and functions of the described products as mounted in the customer's products or equipment. To verify symptoms and states that cannot be evaluated in an independent device, the customer should always evaluate and test devices mounted in the customer's products or equipment.
- SANYO Semiconductor Co.,Ltd. assumes no responsibility for equipment failures that result from using products at values that exceed, even momentarily, rated values (such as maximum ratings, operating condition ranges, or other parameters) listed in products specifications of any and all SANYO Semiconductor Co.,Ltd. products described or contained herein.
- SANYO Semiconductor Co.,Ltd. strives to supply high-quality high-reliability products, however, any and all semiconductor products fail or malfunction with some probability. It is possible that these probabilistic failures or malfunction could give rise to accidents or events that could endanger human lives, trouble that could give rise to smoke or fire, or accidents that could cause damage to other property. When designing equipment, adopt safety measures so that these kinds of accidents or events cannot occur. Such measures include but are not limited to protective circuits and error prevention circuits for safe design, redundant design, and structural design.
- In the event that any or all SANYO Semiconductor Co.,Ltd. products described or contained herein are controlled under any of applicable local export control laws and regulations, such products may require the export license from the authorities concerned in accordance with the above law.
- No part of this publication may be reproduced or transmitted in any form or by any means, electronic or mechanical, including photocopying and recording, or any information storage or retrieval system, or otherwise, without the prior written consent of SANYO Semiconductor Co.,Ltd.
- Any and all information described or contained herein are subject to change without notice due to product/technology improvement, etc. When designing equipment, refer to the "Delivery Specification" for the SANYO Semiconductor Co.,Ltd. product that you intend to use.
- Information (including circuit diagrams and circuit parameters) herein is for example only; it is not guaranteed for volume production.
- Upon using the technical information or products described herein, neither warranty nor license shall be granted with regard to intellectual property rights or any other rights of SANYO Semiconductor Co.,Ltd. or any third party. SANYO Semiconductor Co.,Ltd. shall not be liable for any claim or suits with regard to a third party's intellectual property rights which has resulted from the use of the technical information and products mentioned above.

This catalog provides information as of June, 2011. Specifications and information herein are subject to change without notice.